



DG/JIG



trend[®]
routing technology



Please read these instructions before use.

Dear Customer

Thank you for purchasing this Trend product, we hope you enjoy many years of creative and productive use.

Please remember to return your guarantee card within 28 days of purchase.

CONTENTS

TECHNICAL DATA	1
SAFETY	2-3
ITEMS ENCLOSED	4
DESCRIPTION OF PARTS	5
ASSEMBLY	
– Guide Bushes	6
– Setting up the Router	6
OPERATION	
– Positioning Jig on Worktop	7
– Setting the Depth of Cut	8
– Routing the Groove	8
– Shorter Length of Groove	9
– Use Made Stop	9
– Finishing the Draining Groove	9
MAINTENANCE	10
ENVIRONMENTAL PROTECTION	10
GUARANTEE	10
SPARE PARTS	
– Spare Parts List	11
– Spare Parts Diagram	11
TROUBLE SHOOTING	12

TECHNICAL DATA

Jig thickness	10mm
Cutter size	R9.5mm (Ø19mm)
Slot length (approx.)	455mm
Slot depth at sink (approx.)	4.0mm to 4.5mm
Gradient	0.5°
Guide bush size	30mm
Weight	4.3kg

The following symbols are used throughout this manual:



Denotes risk of personal injury, loss of life or damage to the tool in case of non-observance of the instructions in this manual.



Refer to the instruction manual of your power tool.

This unit must not be put into service until it has been established that the power tool to be connected to this unit is in compliance with 2006/42/EC (identified by the CE marking on the power tool).

INTENDED USE

This jig is intended to be used with a plunge router fitted with suitable cutter and guide bush to rout draining grooves in natural wood worktops for Belfast sinks.



Make trial cuts on waste material before using jig on actual worktop.



If you require further safety advice, technical information or spare parts, please call our technical support department or visit www.trend-uk.com

SAFETY



WARNING:

Observe the safety regulations in the instruction manual of the power tool to be used. Please read the following instructions carefully. Failure to do so could lead to serious injury. When using electric tools, basic safety precautions, including the following should always be followed to reduce the risk of fire, electric shock and personal injury. Also observe any applicable additional safety rules. Read the following safety instructions before attempting to operate this product.

PLEASE KEEP THESE INSTRUCTIONS IN A SAFE PLACE.

The attention of UK users is drawn to The Provision and Use of Work Equipment Regulations 1998, and any subsequent amendments.

Users should also read the HSE/HSC Safe Use of Woodworking Machinery Approved Code of Practice and Guidance Document and any amendments.

Users must be competent with woodworking equipment before using our products.

IMPORTANT NOTE:

Residual Risk. Although the safety instructions and operating manuals for our tools contain extensive instructions on safe working with power tools, every power tool involves a certain residual risk which cannot be completely excluded by safety mechanisms. Power tools must therefore always be operated with caution!

General

1. Disconnect power tool and attachment from power supply when not in use, before servicing, when making adjustments and when changing accessories such as cutters. Ensure switch is in "off" position. Always ensure cutter has stopped rotating.
2. Always mount the power tool, accessory or attachment in conformity with the instructions. Only use attachment and accessories specified in the power tool manual. The tool or attachment should not be modified or used for any application other than that for which it was designed. Do not force tool.
3. Keep children and visitors away. Do not let children or visitors touch the tool, accessory or attachment. Keep children and visitors away from work area. Make the workshop child proof with padlock and master switch.
4. Dress properly. Do not wear loose clothing or jewellery, they can be caught in moving parts. Rubber gloves and non-skid footwear is recommended when working

outdoors. Wear protective hair covering to contain long hair.

5. Consider working environment. Do not use the product in the rain or in a damp environment. Keep work area well lit. Do not use power tools near gasoline or flammable liquids. Keep workshop at a comfortable temperature so your hands are not cold. Connect machines that are used in the open via a residual current device (RCD) with an actuation current of 30 mA maximum. Use only extension cables that are approved for outdoor use.
6. The accessory or attachment must be kept level and stable at all times.
7. Keep work area clean. Cluttered workshops and benches can cause injuries. Ensure there is sufficient room to work safely.
8. Secure idle tools. When not in use, tools should be stored in a dry and high or locked up place, out of reach of children.
9. For best control and safety use both hands on the power tool and attachment. Keep both hands away from cutting area. Always wait for the spindle and cutter to stop rotating before making any adjustments.
10. Always keep guards in place and in good working order.
11. Remove any nails, staples and other metal parts from the workpiece.
12. Maintain tools and cutters with care. Keep cutters sharp and clean for better and safer performance. Do not use damaged cutters. Follow instructions for lubricating and changing accessories. Keep handles dry, clean and free from oil and grease.
13. Maintain accessories. Do not use damaged accessories. Only use accessories recommended by the manufacturer.
14. Check damaged parts. Before operation inspect the attachment, the power tool, the cable, extension cable and the plug carefully for signs of damage. Check for alignment of moving parts, binding, breakage, mounting and any other conditions that may effect its operation. Have any damage repaired by an Authorised Service Agent before using the tool or accessory. Protect tools from impact and shock.
15. Do not use tool if switch does not turn it on or off. Have defective switches replaced by an Authorised Service Agent
16. Don't over reach. Keep proper footing and balance at all times. Do not use

awkward or uncomfortable hand positions.

17. Don't abuse the cable. Never carry power tool or accessory by cord or pull it to disconnect from the socket. Keep cord from heat, oil and sharp edges. Always trail the power cord away from the work area.
18. Connect dust extraction equipment. If devices are provided for the connection of dust extraction and collection facilities, ensure these are connected and properly used.
19. Check all fixing and fastening nuts, bolts and screws on power tool, attachment and cutting tools before use to ensure they are tight and secure. Periodically check when machining over long periods.
20. Stay alert. Watch what you are doing. Use common sense. Do not operate tools when you are tired, under the influence of drugs or alcohol.
21. Personal Protective Equipment (PPE) for eye, ear and respiratory protection must be worn. All PPE must meet current UK and EU legislation.
22. Do not leave tools running unattended. Do not leave tool until it comes to a complete stop.
23. Always clamp workpiece being machined securely.
24. Only use cutting tools for woodworking that meet EN847-1/2 safety standards, and any subsequent amendments.
25. Vibration levels. Hand held power tools produce different vibration levels. You should always refer to the specifications and relevant Health & Safety Guide.

Routing Safety

1. Read and understand instructions supplied with power tool, attachment and cutter.
2. Keep hands, hair and clothing clear of the cutter.
3. Remove adjusting keys and spanners. Check to see that keys and adjusting spanners are removed from the router tool, cutter and attachment before turning router on. Make sure cutter can rotate freely.
4. Noise. Take appropriate measures for the protection of hearing if the sound pressure of 85dB(A) is exceeded. Routing sound pressure may exceed 85dB(A), so ear protection must be worn.
5. Eye protection. Always wear eye protection in the form of safety goggles, spectacles or visors to protect the eyes.

6. Respiratory protection. Wear a face or dust mask, or powered respirator. Dust masks/filters should be changed regularly.
7. Do not switch router on with the cutter touching the workpiece. At the end of the cut, release the router plunge and allow spindle to stop rotating. Never use the spindle lock as a brake
8. The direction of routing must always be opposite to the cutter's direction of rotation. Do not back-cut or climb-cut.
9. Check before cutting that there are no obstructions in the path of the router. Ensure there are no obstacles beneath workpiece when cutting full thickness, and that a sacrificial work surface is used.

Router Cutter Safety

1. Cutting tools are sharp. Care should be taken when handling them. Do not drop cutters or knock them against hard objects. Handle very small diameter cutters with extra care. Always return cutter to its packaging after use.
2. Always use cutters with a shank diameter corresponding to the size of the collet installed in your tool.
3. The maximum speed (n.max) marked on the tool, or in instructions or on packaging shall not be exceeded. Where stated the speed range shall be adhered to. Recommended speeds are shown in the Trend Routing Catalogue and/or website.
4. Always use router cutters in a router. Drill and boring bits must not be used in a router. Router cutters must only be used for the material cutting application for which they are designed. Do not use on metal or masonry.
5. Never use cutters with a diameter exceeding the maximum diameter indicated in the technical data of the powertool or attachment used.
6. Before each use check that the cutting tool is sharp and free from damage. Do not use the cutting tool if it is dull, broken or cracked or if in any other damage is noticeable or suspected.
7. Cutters should be kept clean. Resin build up should be removed at regular intervals with Resin Cleaner[®]. The use of a PTFE dry lubricant will reduce resin build up. Do not use PTFE spray on plastic parts.
8. When using stacked tooling (multi-blade, block and groover etc.) on a spindle arbor, ensure that the cutting edges are staggered to each other to reduce the cutting impact.
9. Cutter shanks should be inserted into the collet all the way to the line

indicated on the shank. This ensures that at least $\frac{3}{4}$ of the shank length is held in the collet. Ensure clamping surfaces are cleaned to remove dirt, grease, oil and water.

10. Observe the correct assembly and fitting instructions in the router instruction manual for fitting the collet, nut and cutter.
11. Tool and tool bodies shall be clamped in such a way that they will not become loose during operation. Care shall be taken when mounting cutting tools to ensure that the clamping is by the shank of the cutting tool and that the cutting edges are not in contact with each other or with the clamping elements.
12. It is advisable to periodically check the collet and collet nut. A damaged, worn or distorted collet and nut can cause vibration and shank damage. Do not over-tighten the collet nut
13. Do not take deep cuts in one pass; take several shallow or light passes to reduce the side load applied to the cutter and router. Too deep a cut in one pass can stall the router.
15. In case of excessive vibrations whilst using the router stop immediately and have the eccentricity of the router, router cutter and clamping system checked by competent personnel
15. All fastening screws and nuts should be tightened using the appropriate spanner or key and to the torque value provided by the manufacturer.
16. Extension of the spanner or tightening using hammer blows shall not be permitted.
17. Clamping screws shall be tightened according to instructions provided by the manufacture. Where instructions are not provided, clamping screws shall be tightened in sequence from the centre outwards.

Using Routers In A Fixed Position

1. Attention should be made to the HSE's Safe Use of Vertical Spindle Moulding Machines Information Sheet No.18 and any revisions.
2. After work, release the router plunge to protect the cutter.
3. Always use a push-stick or push-block when making any cut less than 300mm in length or when feeding the last 300mm of the cut.
4. The opening around the cutter should be reduced to a minimum using suitably sized insert rings in the table and closing the back fence cheeks or fitting a false fence on the back fence.
5. Whenever possible use a work holding device or jig to secure

component being machined. Ensure any attachment is securely fitted to the workbench, with table surface at approximately hip height.

6. Use a No-Volt Release Switch. Ensure it is fixed securely, easily accessible and used correctly.
7. In router table (inverted) mode, stand to the front right of the table. The cutter will rotate anti-clockwise when viewed from top so the feed direction is from the right (against the rotation of the cutter). In overhead mode, stand to the front left of the machine table and the feed direction is from the left.
8. Do not reach underneath table or put your hands or fingers at any time in the cutting path while tool is connected to a power supply.
9. Never thickness timber between the back of the cutter and the backfence.

Useful Advice When Routing

1. Judge your feed rate by the sound of the motor. Feed the router at a constant feed rate. Too slow a feed rate will result in burning.
2. Trial cuts should be made on waste material before starting any project.
3. When using some attachments e.g. a router table or dovetail jig, a fine height adjuster is recommended.
4. When using a template guide bush, ensure there is sufficient clearance between cutter tip and inside edge of bush and that it cannot come into contact with collet and nut. Ensure cutter and guide bush are concentric.

Router Cutter Repair/Maintenance

1. Repair of tools is only allowed in accordance with the manufacturers instructions.
3. The design of composite (tipped) tools shall not be changed in process of repair. Composite tools shall be repaired by a competent person i.e. a person of training and experience, who has knowledge of the design requirements and understands the levels of safety to be achieved.
4. Repair shall therefore include, e.g. the use of spare parts which are in accordance with the specification of the original parts provided by the manufacturer.
5. Tolerances which ensure correct clamping shall be maintained.
6. Care shall be taken that regrinding of the cutting edge will not cause weakening of the body and the connection of the cutting edge to the body.

ITEMS ENCLOSED

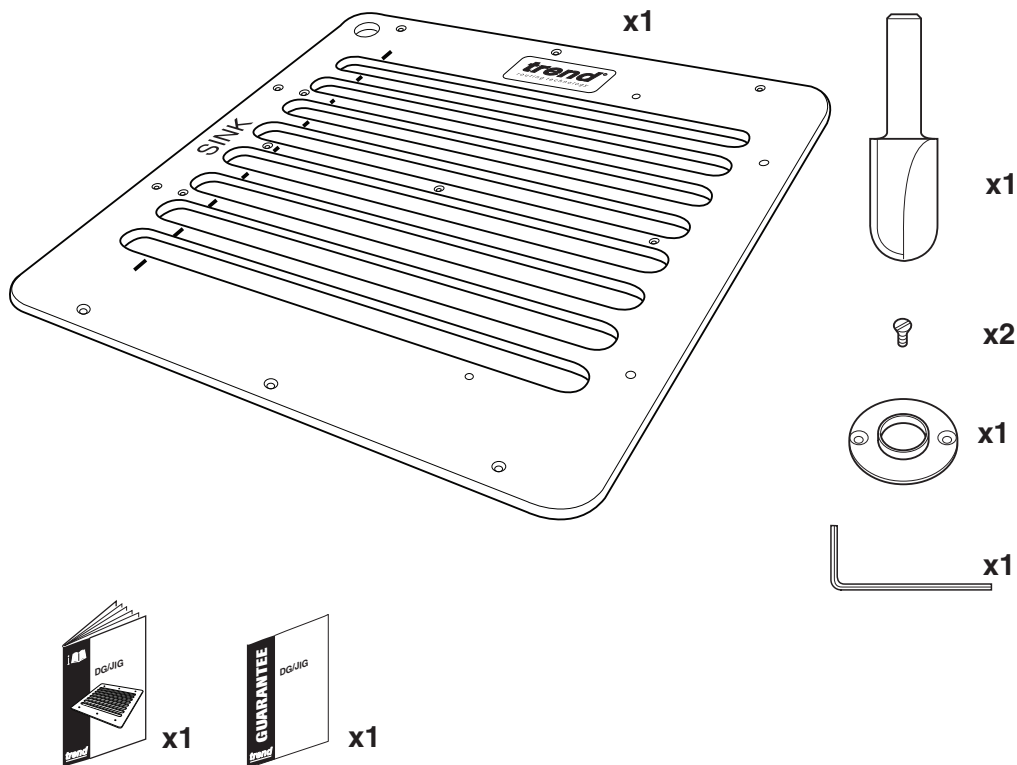

ITEMS REQUIRED

- 1/2" plunge router.
- Trestles x 2.
- Clamps x 3.
- Hand tools.

Ref. UNIBASE

For certain makes of router, a sub-base will be required to allow the guide bush to be fitted.

DESCRIPTION OF PARTS

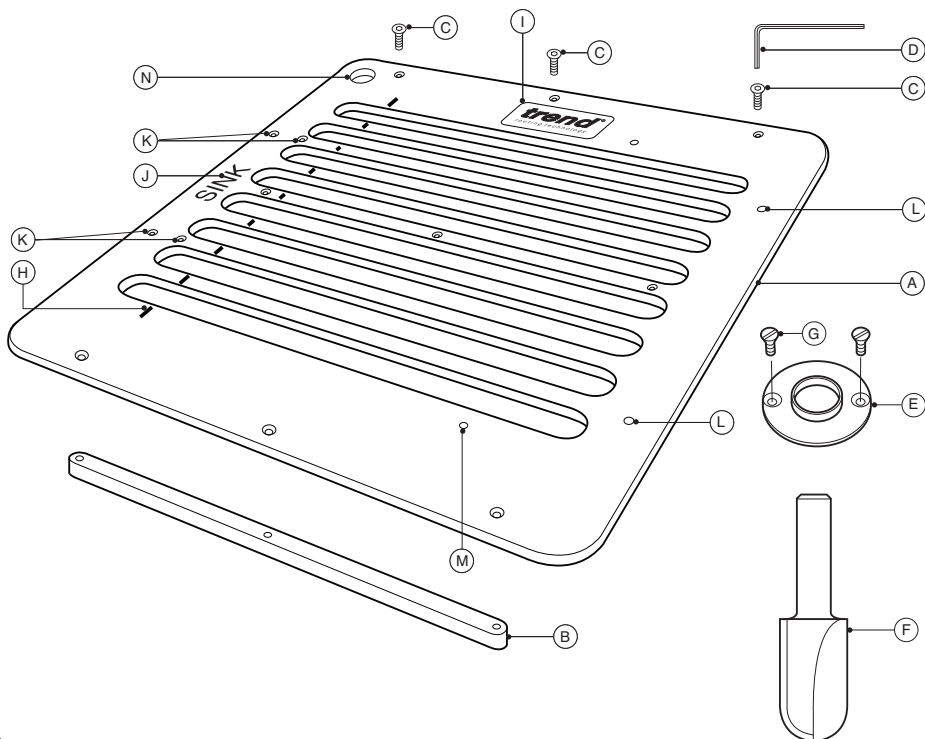

- (A) Jig body
- (B) Tapered rail (supplied pre-fitted)
- (C) Fixing screw (supplied pre-fitted)
- (D) Hex key
- (E) Guide bush 30mmØ
- (F) Cove router cutter R9.5mm x 32mm cut
- (G) Guide bush fixing screw
- (H) Sight mark
- (I) Label (top of jig)
- (J) Sink indicator (shows direction of slope to sink)
- (K) Fixing holes for user made stop facility
- (L) Hanging holes
- (M) Fixing holes for user made batten for 300mm long grooves
- (N) Hole to check cutter diameter of 19.1mm

ASSEMBLY

Guide Bushes

The bush supplied with the jig is the standard Trend pattern. It will fit Trend routers directly.

For other makes and model of router a sub-base may be required to allow the guide bush to be fitted. Ref. UNIBASE has been designed for use with a variety of routers; it also ensures concentricity between cutter and guide bush ensuring accuracy.

Setting up the Router

- Isolate router from power supply.
- Fit guide bush to router.
- Fit router cutter into router.

Worktop

- Position the kitchen worktop onto the units and mark out aperture for Belfast sink as per sink manufacturers instructions. Cut out the aperture as per sink manufacturers instructions.
- Cut an anti-drip groove on the underside of the worktop around the sink perimeter aperture.
- Move worktop jig away from units as all round access is required for clamping jig to the worktop.

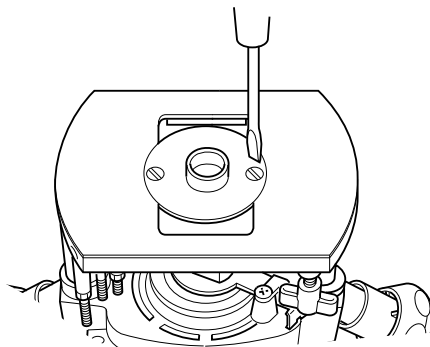

Before cutting an actual worktop, make trial cuts on a waste piece of worktop to check groove depth and spacing is correct and to allow familiarisation of jig.



The jig has a 19.1mm gauge hole on the back left corner so that cutter diameter can be quickly checked.



Ensure worktop is clamped and held securely when using the jig.

OPERATION



Positioning Jig on Worktop

- Mark the worktop to denote which side the draining grooves are required. Decide if grooves are required on the left or right or both sides of the sink.
- Using the jig as a guide mark the first and last groove position. The groove pitch (centre to centre) is 50mm. The nearest edge of the first groove must be a minimum of 100mm from the front edge of the worktop. The grooves should be ideally equidistant to the sink aperture, but this will be dictated by the sink size. Double check pencil mark positions of grooves and adjust if necessary.
- Position the jig on the worktop to the marked pencil lines, then using the sight marks on the jig align the marks to the edge of the worktop. Re-check position.
- Clamp jig to the worktop using three clamps, ensuring the clamps will not foul the router base and that clamps are inboard of the rails. Do not clamp on the very edges of the jig.
- The clamps may need to be repositioned for grooves towards front and back of the jig. If clamping towards end of the slots ensure the top of the template does not lift.



Ensure working position is comfortable. Keep proper footing and balance at all times.



Ensure clamps are inboard of the rails.



Ensure worktop is of a suitable size to support jig.



To prevent damaging the jig make sure the router's plunge is fully released after completing the cut.

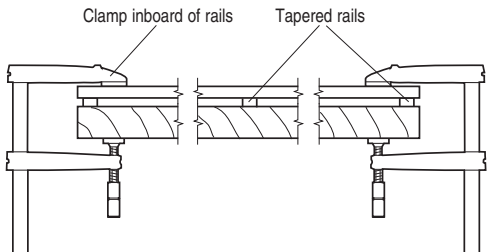
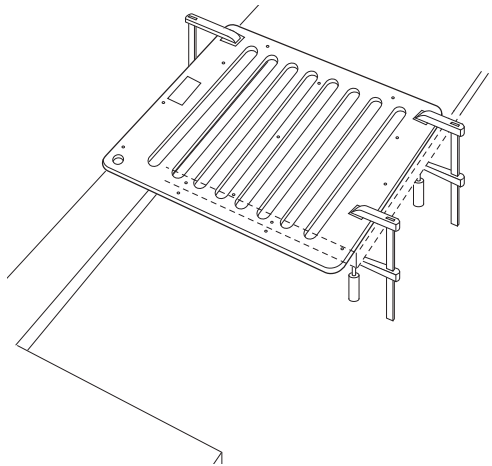
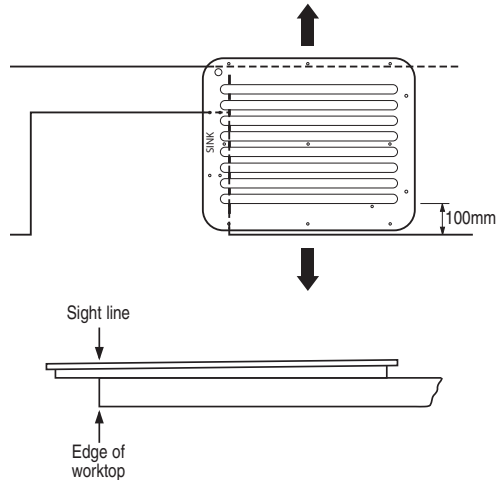

Setting the Depth of Cut

- Set the router with guide bush fitted into one slot and position router to the shallow end of the jig ensuring that the worktop can be seen below the cutter.
- Plunge router down until the cutter is just touching the worktop.
- Set the router depth stop 4mm (maximum 4.5mm deep).



A 0.5mm difference in depth of cut can make a considerable difference to the finished groove.

Routing the Groove

- Release plunge and reposition router in first slot at sink end.
- Hold router against the far edge of the template slot (towards top of jig).
- Switch on router and plunge to height setting. Rout groove feeding up the slope away from the sink end using a slow feed. The slot in the jig will limit the length of the groove. The groove depth in the worktop will get shallower.
- At the end of the cut move router against the near edge of the slot and rout back down the slot towards the sink. The slots are 0.2mm oversize to allow for return pass. Ensure the router cutter passes out of the wood at the sink end.
- Release plunge and switch off router.
- Repeat this operation for each slot in the jig as required.
- Before removing the jig, check all slots are routed to the correct length and correct depth. If any of the grooves are not correct, adjust the depth of cut accordingly and recut.

After use, keep jig assembled and store properly.



Depending on the groove arrangement the first slot on the jig front may not need to be used.

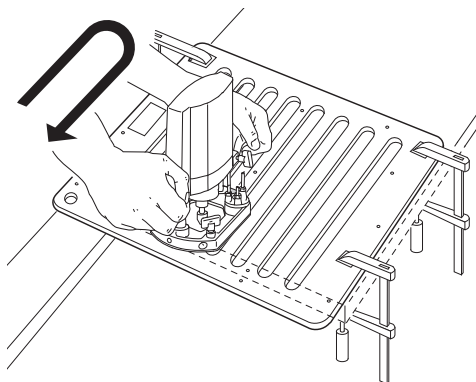
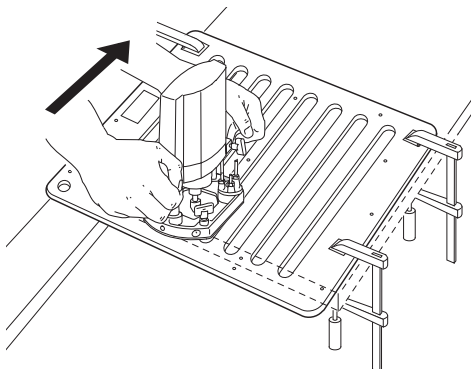
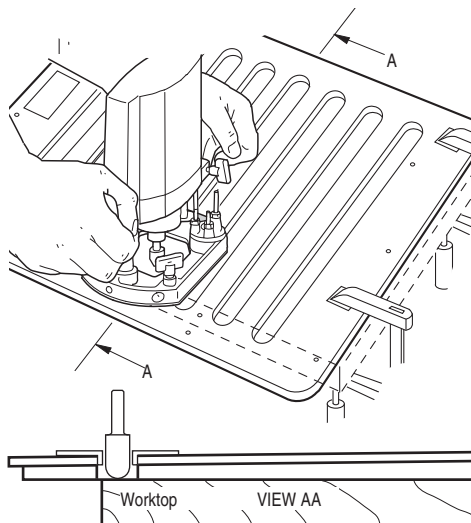

Shorter Length of Groove 

The groove length can be made shorter to approximately 300mm long by fixing a user made batten (12mm thick, 50mm wide x 500mm long) to the top of the jig. This batten will deliberately restrict the movement of the router. The batten position will need to be calculated by the user as it will vary depending on the make and model of the router used. The batten should be placed on top of the jig and secured from underneath using screws through the holes in the jig body.

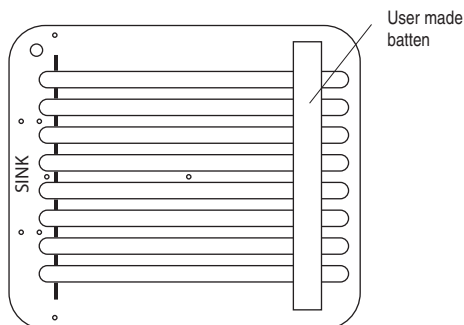

User Made Stop 

For repetitive work, two user made stops can be made and fitted to the front edge of the slots. The jig has two fixing holes to accept No.8 countersink screws for each stop. The stops should be made from 18mm thick MDF, size 50mm wide x 100mm long. Line up edge of the stops to the sight line and secure with countersink screws. The first time the stops are used, the router cutter will need to plunge into the stop.

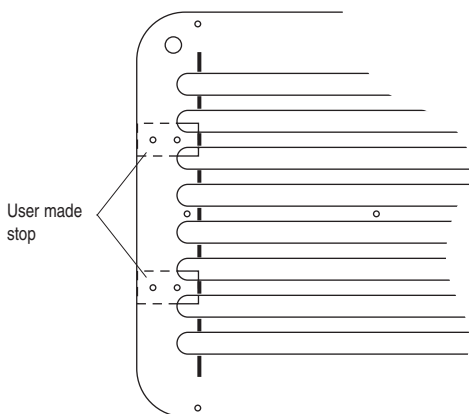

A hex key is supplied if tapered rails need to be removed. When refitting ensure the tapered rails are the correct way round.

Finishing the Draining Groove 

- When routing is complete, remove any rough edges with fine grade abrasive paper.
- Finish and seal the worktop with appropriate sealer, following worktop manufacturers instructions.

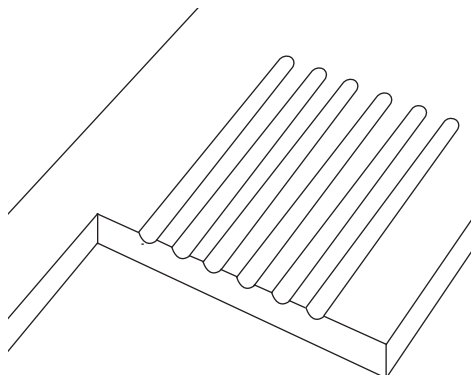

MAINTENANCE

Please use only Trend original spare parts and accessories.

The jig has been designed to operate over a long period of time with a minimum of maintenance. Continual satisfactory operation depends upon proper tool care and regular cleaning.

Cleaning

- Regularly clean the jig with a soft cloth.
- Ensure clamping surfaces on cutter and collet are cleaned to remove dirt, grease, oil and water.
- Apply a rust protector to shanks. Do not use rust protector on ball bearing guides.

Lubrication

- Your jig requires no additional lubrication.
- Use a PTFE dry lubricant spray on the cutting tool to increase cutting edge life.

Storage

- Always return cutter to its original packaging after use.
- After use jig can be hung on a wall using the two hanging holes.
- An accessory case is also available Ref. CASE/DG.



ENVIRONMENTAL PROTECTION

Recycle raw materials instead of disposing as waste.

Packaging should be sorted for environmental-friendly recycling.

The product and its accessories at the end of their life should be sorted for environmental friendly recycling.

GUARANTEE

The jig carries a manufacturers guarantee in accordance with the conditions on the enclosed guarantee card.

DG/JIG - SPARE PARTS DIAGRAM

v1.0 08/2006

Please use only Trend original spare parts.

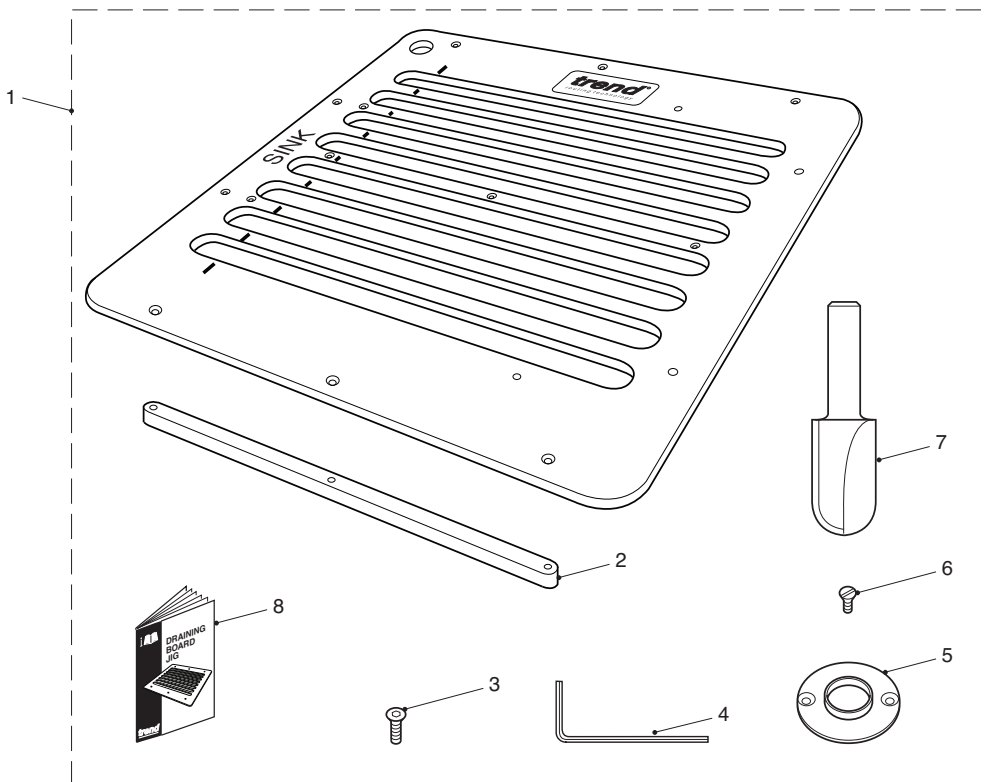

DG/JIG - SPARE PARTS LIST			v1.0 08/2006
No.	Qty.	Desc.	Ref.
1	1	Draining Groove Jig	DG/JIG
2	1	Tapered Rail (pack of Three)	WP-DG/01
3	9	Machine Screw Csk M5 x 20mm Skt	WP-SCW/60
4	1	Hex Key 3mm A/F	WP-AP/03
5	1	Guide Bush 30mm x 6mm	GB30
6	2	Machine Screw Csk M5 x 8mm Slot	WP-SCW/09
7	1	Cove Cutter R9.5 x 32mm Cut	C056AX1/2TC
8	1	Manual	MANU/DG

TROUBLE SHOOTING

Fault	Cause	Remedy
■ Groove depth tapers to a point at shallow end.	Cutter depth too shallow. Jig has lifted when clamped.	Set depth to approx. 4.5mm. Ensure clamps are inboard of tapered rails. Reposition clamps.
■ Groove depth vary between slots.	Jig has lifted when clamped. Jig not clamped correctly.	Ensure clamps are inboard of tapered rails. Reposition clamps.
■ Groove depth tapers too deep at shallow end.	Cutter depth too deep.	Replace worktop and set depth to approximately 4mm.
■ The taper slot at shallow end has a slight gouge at the end of the cut.	Return pass in slot not carried out. Slot is 0.2mm oversize to allow for return pass.	Rout along inside edge of slot on return pass.
■ Groove gets deeper away from sink.	Jig fitted wrong way round on worktop.	Replace worktop, check jig orientation and re-cut.
■ Jig lifts up when clamped.	Jig clamped at the end of slots.	Reposition clamps so jig does not lift when clamped. Ensure router does not foul clamps.
■ Centre of jig lifts when clamped.	Clamps not inboard of runners. Insufficient number of clamps used.	Reposition clamps so that they are inboard of the tapered rails. Use three clamps.
■ Groove too wide or too narrow.	Wrong cutter size or guide bush used.	Use a 30mm guide bush and 9.5mm radius cove cutter. (19.1mm diameter)
■ Grooves not central to sink, or at an angle.	Jig not set correctly to sight line and edge of worktop.	Re-set ensuring sight line is in line with worktop edge.
■ Groove in worktop is burnt.	Cutter blunt.	Always use sharp cutters.
■ Jig is slipping on material.	Clamps not secure or too deep a cut being taken.	Check clamps for wear. Clamp securely. Take shallower passes. Use a sharp cutter.

MANU/DG v3.0



RECYCLABLE

Trend Machinery & Cutting Tools Ltd.

Odhams Trading Estate St Albans Road

Watford WD24 7TR England

Tel: 0044(0)1923 249911

technical@trendm.co.uk

www.trend-uk.com