



LOCK/JIG/B



trend[®]
routing technology



Please read these instructions before use.

Dear Customer

Thank you for purchasing this Trend product, we hope you enjoy many years of creative and productive use.

Please remember to return your guarantee card within 28 days of purchase.

CONTENTS

TECHNICAL DATA	1
SAFETY PRECAUTIONS	2-3
ITEMS ENCLOSED	4
DESCRIPTION OF PARTS	5
ACCESSORIES	6
ASSEMBLY	7
- Choice of Router Set-up	8
- Fitting the Guide Bush	9
OPERATION	
- Marking Out	10
- Centering the Jig	11
- Setting the Aperture Size	12
- Setting the Mortise Width	12
- Setting the Mortise Length	13
- Setting Faceplate Width & Length	14
- Routing the Mortise	15
- Routing the Faceplate	15
- Finishing	16
- Deeper Mortise	16
- Cutting Key & Spindle Holes	16
MAINTENANCE	16
ENVIRONMENT PROTECTION	16
GUARANTEE	16
SPARE PARTS	
- Spare Parts List	IB
- Spare Parts Diagram	IB

TECHNICAL DATA

Cutter size	12mm
Min. workpiece	30mm
Max. workpiece	80mm
Min. width	16mm
Max. width	25.4mm
Max. faceplate length	250mm
Guide bush size	30mm
Weight	1.4kg

The following symbols are used throughout this manual:



Denotes risk of personal injury, loss of life or damage to the tool in case of non-observance of the instructions in this manual.



Refer to the instruction manual of your power tool.

This unit must not be put into service until it has been established that the power tool to be connected to this unit is in compliance with 2006/42/EC (identified by the CE marking on the power tool).

INTENDED USE

This jig is intended for use with a plunge router with suitable guide bush and router cutter fitted to rout a mortise and face plate for locks in wooden doors.



If you require further safety advice, technical information or spare parts, please call Trend Technical Support or visit www.trend-uk.com

SAFETY



WARNING:

Observe the safety regulations in the instruction manual of the power tool to be used. Please read the following instructions carefully. Failure to do so could lead to serious injury. When using electric tools, basic safety precautions, including the following should always be followed to reduce the risk of fire, electric shock and personal injury. Also observe any applicable additional safety rules. Read the following safety instructions before attempting to operate this product.

PLEASE KEEP THESE INSTRUCTIONS IN A SAFE PLACE.

The attention of UK users is drawn to The Provision and Use of Work Equipment Regulations 1998, and any subsequent amendments.

Users should also read the HSE/HSC Safe Use of Woodworking Machinery Approved Code of Practice and Guidance Document and any amendments.

Users must be competent with woodworking equipment before using our products.

IMPORTANT NOTE:

Residual Risk. Although the safety instructions and operating manuals for our tools contain extensive instructions on safe working with power tools, every power tool involves a certain residual risk which cannot be completely excluded by safety mechanisms. Power tools must therefore always be operated with caution!

General

1. Disconnect power tool and attachment from power supply when not in use, before servicing, when making adjustments and when changing accessories such as cutters. Ensure switch is in "off" position. Always ensure cutter has stopped rotating.
2. Always mount the power tool, accessory or attachment in conformity with the instructions. Only use attachment and accessories specified in the power tool manual. The tool or attachment should not be modified or used for any application other than that for which it was designed. Do not force tool.
3. Keep children and visitors away. Do not let children or visitors touch the tool, accessory or attachment. Keep children and visitors away from work area. Make the workshop child proof with padlock and master switch.
4. Dress properly. Do not wear loose clothing or jewellery, they can be caught in moving parts. Rubber gloves and non-skid footwear is recommended when working

outdoors. Wear protective hair covering to contain long hair.

5. Consider working environment. Do not use the product in the rain or in a damp environment. Keep work area well lit. Do not use power tools near gasoline or flammable liquids. Keep workshop at a comfortable temperature so your hands are not cold. Connect machines that are used in the open via a residual current device (RCD) with an actuation current of 30 mA maximum. Use only extension cables that are approved for outdoor use.
6. The accessory or attachment must be kept level and stable at all times.
7. Keep work area clean. Cluttered workshops and benches can cause injuries. Ensure there is sufficient room to work safely.
8. Secure idle tools. When not in use, tools should be stored in a dry and high or locked up place, out of reach of children.
9. For best control and safety use both hands on the power tool and attachment. Keep both hands away from cutting area. Always wait for the spindle and cutter to stop rotating before making any adjustments.
10. Always keep guards in place and in good working order.
11. Remove any nails, staples and other metal parts from the workpiece.
12. Maintain tools and cutters with care. Keep cutters sharp and clean for better and safer performance. Do not use damaged cutters. Follow instructions for lubricating and changing accessories. Keep handles dry, clean and free from oil and grease.
13. Maintain accessories. Do not use damaged accessories. Only use accessories recommended by the manufacturer.
14. Check damaged parts. Before operation inspect the attachment, the power tool, the cable, extension cable and the plug carefully for signs of damage. Check for alignment of moving parts, binding, breakage, mounting and any other conditions that may affect its operation. Have any damage repaired by an Authorised Service Agent before using the tool or accessory. Protect tools from impact and shock.
15. Do not use tool if switch does not turn it on or off. Have defective switches replaced by an Authorised Service Agent
16. Don't over reach. Keep proper footing and balance at all times. Do not use

awkward or uncomfortable hand positions.

17. Don't abuse the cable. Never carry power tool or accessory by cord or pull it to disconnect from the socket. Keep cord from heat, oil and sharp edges. Always trail the power cord away from the work area.
18. Connect dust extraction equipment. If devices are provided for the connection of dust extraction and collection facilities, ensure these are connected and properly used.
19. Check all fixing and fastening nuts, bolts and screws on power tool, attachment and cutting tools before use to ensure they are tight and secure. Periodically check when machining over long periods.
20. Stay alert. Watch what you are doing. Use common sense. Do not operate tools when you are tired, under the influence of drugs or alcohol.
21. Personal Protective Equipment (PPE) for eye, ear and respiratory protection must be worn. All PPE must meet current UK and EU legislation.
22. Do not leave tools running unattended. Do not leave tool until it comes to a complete stop.
23. Always clamp workpiece being machined securely.
24. Only use cutting tools for woodworking that meet EN847-1/2 safety standards, and any subsequent amendments.
25. Vibration levels. Hand held power tools produce different vibration levels. You should always refer to the specifications and relevant Health & Safety Guide.

Routing Safety

1. Read and understand instructions supplied with power tool, attachment and cutter.
2. Keep hands, hair and clothing clear of the cutter.
3. Remove adjusting keys and spanners. Check to see that keys and adjusting spanners are removed from the router tool, cutter and attachment before turning router on. Make sure cutter can rotate freely.
4. Noise. Take appropriate measures for the protection of hearing if the sound pressure of 85dB(A) is exceeded. Routing sound pressure may exceed 85dB(A), so ear protection must be worn.
5. Eye protection. Always wear eye protection in the form of safety goggles, spectacles or visors to protect the eyes.

6. Respiratory protection. Wear a face or dust mask, or powered respirator. Dust masks/filters should be changed regularly.
7. Do not switch router on with the cutter touching the workpiece. At the end of the cut, release the router plunge and allow spindle to stop rotating. Never use the spindle lock as a brake.
8. The direction of routing must always be opposite to the cutter's direction of rotation. Do not back-cut or climb-cut.
9. Check before cutting that there are no obstructions in the path of the router. Ensure there are no obstacles beneath workpiece when cutting full thickness, and that a sacrificial work surface is used.

Router Cutter Safety

1. Cutting tools are sharp. Care should be taken when handling them. Do not drop cutters or knock them against hard objects. Handle very small diameter cutters with extra care. Always return cutter to its packaging after use.
2. Always use cutters with a shank diameter corresponding to the size of the collet installed in your tool.
3. The maximum speed (n.max) marked on the tool, or in instructions or on packaging shall not be exceeded. Where stated the speed range shall be adhered to. Recommended speeds are shown in the Trend Routing. Always use router cutters in a router. Drill and boring bits must not be used in a router. Router cutters must only be used for the material cutting application for which they are designed. Do not use on metal or masonry.
5. Never use cutters with a diameter exceeding the maximum diameter indicated in the technical data of the power tool or attachment used.
6. Before each use check that the cutting tool is sharp and free from damage. Do not use the cutting tool if it is dull, broken or cracked or if in any other damage is noticeable or suspected.
7. Cutters should be kept clean. Resin build up should be removed at regular intervals with Resin Cleaner. The use of a PTFE dry lubricant will reduce resin build up. Do not use PTFE spray on plastic parts.
8. When using stacked tooling (multi-blade, block and groover etc.) on a spindle arbor, ensure that the cutting edges are staggered to each other to reduce the cutting impact.
9. Cutter shanks should be inserted into the collet all the way to the line indicated on the shank. This ensures

that at least 3/4 of the shank length is held in the collet. Ensure clamping surfaces are cleaned to remove dirt, grease, oil and water.

10. Observe the correct assembly and fitting instructions in the router instruction manual for fitting the collet, nut and cutter.
11. Tool and tool bodies shall be clamped in such a way that they will not become loose during operation. Care shall be taken when mounting cutting tools to ensure that the clamping is by the shank of the cutting tool and that the cutting edges are not in contact with each other or with the clamping elements.
12. It is advisable to periodically check the collet and collet nut. A damaged, worn or distorted collet and nut can cause vibration and shank damage. Do not over-tighten the collet nut.
13. Do not take deep cuts in one pass; take several shallow or light passes to reduce the side load applied to the cutter and router. Too deep a cut in one pass can stall the router.
14. In case of excessive vibrations whilst using the router stop immediately and have the eccentricity of the router, router cutter and clamping system checked by competent personnel.
15. All fastening screws and nuts should be tightened using the appropriate spanner or key and to the torque value provided by the manufacturer.
16. Extension of the spanner or tightening using hammer blows shall not be permitted.
17. Clamping screws shall be tightened according to instructions provided by the manufacture. Where instructions are not provided, clamping screws shall be tightened in sequence from the centre outwards.

Using Routers In A Fixed Position

1. Attention should be made to the HSE's Safe Use of Vertical Spindle Moulding Machines Information Sheet No.18 and any revisions.
2. After work, release the router plunge to protect the cutter.
3. Always use a push-stick or push-block when making any cut less than 300mm in length or when feeding the last 300mm of the cut.
4. The opening around the cutter should be reduced to a minimum using suitably sized insert rings in the table and closing the back fence cheeks or fitting a false fence on the back fence.
5. Whenever possible use a work holding device or jig to secure component being machined. Ensure

any attachment is securely fitted to the workbench, with table surface at approximately hip height.

6. Use a No-Volt Release Switch. Ensure it is fixed securely, easily accessible and used correctly.
7. In router table (inverted) mode, stand to the front right of the table. The cutter will rotate anti-clockwise when viewed from top so the feed direction is from the right (against the rotation of the cutter). In overhead mode, stand to the front left of the machine table and the feed direction is from the left.
8. Do not reach underneath table or put your hands or fingers at any time in the cutting path while tool is connected to a power supply.
9. Never thickness timber between the back of the cutter and the backfence.

Useful Advice When Routing

1. Judge your feed rate by the sound of the motor. Feed the router at a constant feed rate. Too slow a feed rate will result in burning.
2. Trial cuts should be made on waste material before starting any project.
3. When using some attachments e.g. a router table or dovetail jig, a fine height adjuster is recommended.
4. When using a template guide bush, ensure there is sufficient clearance between cutter tip and inside edge of bush and that it cannot come into contact with collet and nut. Ensure cutter and guide bush are concentric.

Router Cutter Repair/Maintenance

1. Repair of tools is only allowed in accordance with the manufacturers instructions.
2. The design of composite (tipped) tools shall not be changed in process of repair. Composite tools shall be repaired by a competent person i.e. a person of training and experience, who has knowledge of the design requirements and understands the levels of safety to be achieved.
3. Repair shall therefore include, e.g. the use of spare parts which are in accordance with the specification of the original parts provided by the manufacturer.
4. Tolerances which ensure correct clamping shall be maintained.
5. Care shall be taken that regrinding of the cutting edge will not cause weakening of the body and the connection of the cutting edge to the body.

ITEMS ENCLOSED

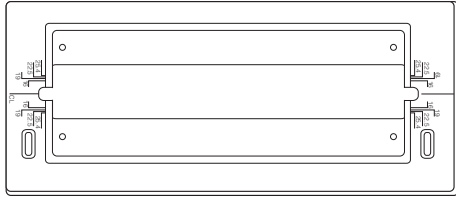

x1

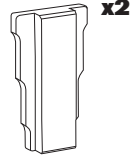

x2

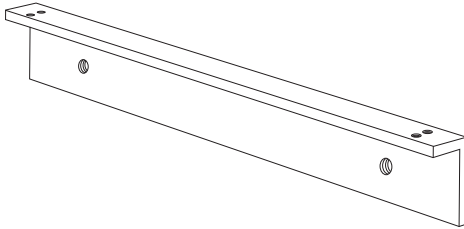

x1



x4



x2

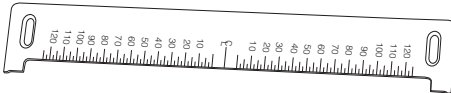

x1



x1

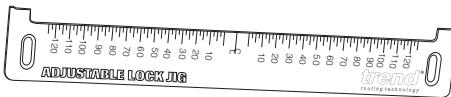

x1



x1



x2

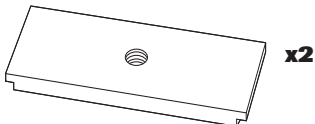

x2

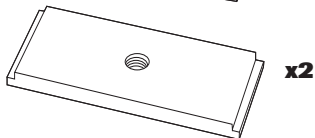

x2

ITEMS REQUIRED

- 1/2" collet plunge router (or 1/4" collet plunge router for face plate only).
- 30mm guide bush (or 16mm plus collar).
- 12mm diameter router cutter with suitable shank size.
- Door clamping device.
- Hand tools.
- No. 2 Pozzi® Screwdriver.
- Clamps x 2.

DESCRIPTION OF PARTS

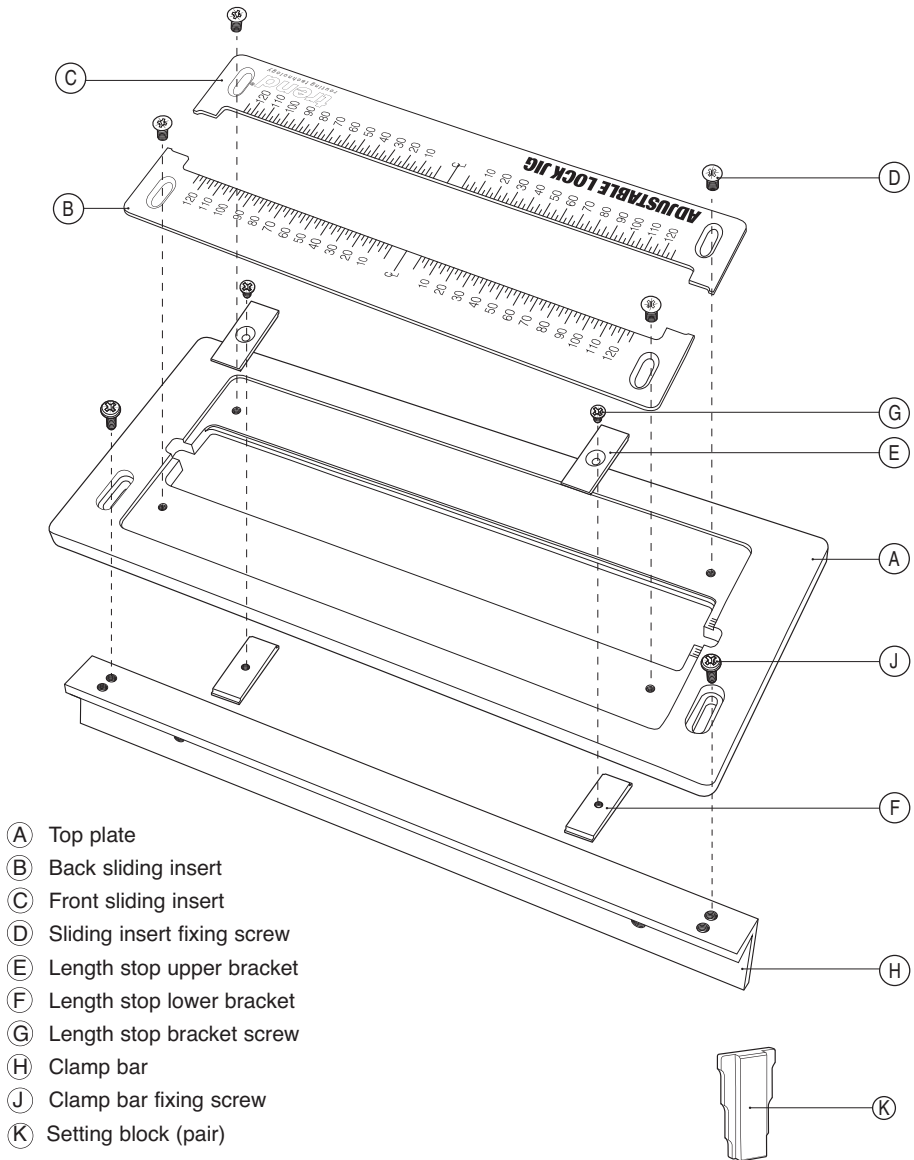

- Ⓐ Top plate
- Ⓑ Back sliding insert
- Ⓒ Front sliding insert
- Ⓓ Sliding insert fixing screw
- Ⓔ Length stop upper bracket
- Ⓕ Length stop lower bracket
- Ⓖ Length stop bracket screw
- Ⓗ Clamp bar
- Ⓙ Clamp bar fixing screw
- Ⓚ Setting block (pair)

ACCESSORIES

Please use only Trend original accessories.

30mm Guide Bush

Ref. GB30/A

Should the correct guide bush not be available to suit your router's base, you will need to use the Trend UNIBASE in conjunction with a 30mm guide bush, Ref. GB30 or 16mm guide bush Ref. GB160.



Universal Sub-base

Ref. UNIBASE

The Unibase contain screws, a line up bush and pin. The line up pin and bush ensure exact alignment of sub-base with the router spindle, when fitted with the relevant collet.

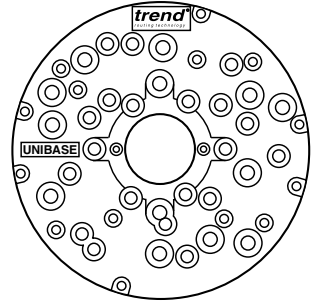

Fits following router models

Atlas Copco OFSE2000 Bosch GOF 1300ACE, 1600A, 1700ACE

Casals FT2000VCE CMT CMT1850, 2000, DeWalt DW624, 625EK, 629 Draper R1900V

Elu MOF 131, 177(E) Felisatti TP246(E), R346EC Festo OF2000E Freud FT2000E Hitachi M12V, M12SA, TR12 Metabo OF1612, OFE1812 Ryobi RE600N, R600N, RE601, R500, R502 Skil 1875U1 Wadkin R500

Gripper Clamps

Ref. FC/200

(2 required)

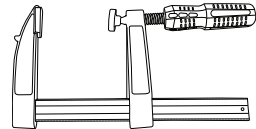

Door Stand

Ref. D/STAND/A

Holds door on it's edge whilst routing hinge recess and mortise for locks. Maximum weight 50kg and for doors 32mm to 55mm thick. Allows door to be tilted back to assist fitting to door frame.

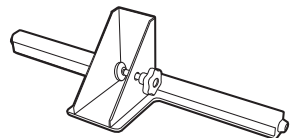

Door Clamp

Ref. D/CLAMP/A

Holds door whilst drilling and fitting locks. Ratchet clamp design for doors up to 55mm thick.

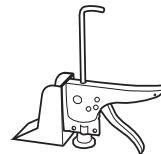

Corner Chisel

Ref. C/CHISEL

Squares up rounded corners in one operation. High speed steel. Use with a hammer.



24" Carry Case

Ref. CASE/DH

Accepts Door Stand, Lock Jig, Door Clamp and accessories.

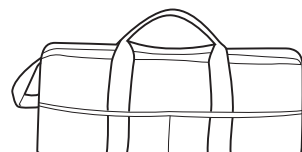

ASSEMBLY

The jig is partially assembled. Fit the clamp bar to the jig body using the two M6 machine screws provided. The clamp bar has two sets of holes to suit different door thicknesses.

Choice of Router Set-ups

Option 1

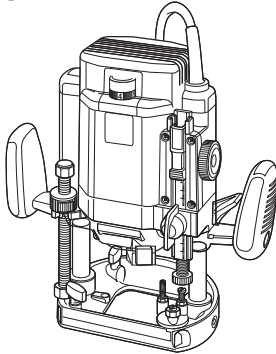

Heavy duty router with 1/2" collet e.g. T10/T11 Router

Suitable Plunge Router:

Your router should have following plunge length:

- For 2" deep locks at least 54mm.
- For 2 1/2" deep locks at least 66mm.
- Auger bit and drill required for 3" deep locks for all routers.



Fit sufficient length of the shank into the collet. Ideally at maximum plunge, only as much of the cutter should protrude below the base as is required to reach the depth of the mortise.



Do not attempt to increase the depth of cut by having less than the optimum length of the cutter's shank inserted in the collet of your router.

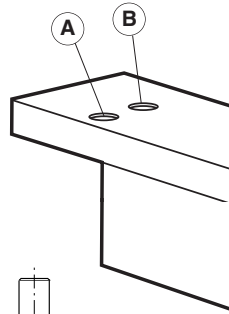

Hole A

Door width 30-64mm

Hole B

Door width 48-80mm

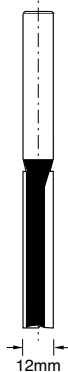

Router Cutter
Ref. TR37X1/2TC
overall length 115mm

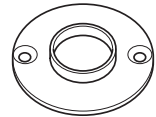

30mm Guide Bush Ref. GB30/A

See page 6 if a suitable guide bush is not available for your router.

OR USE

Router Cutter
Ref. TR37MX1/2TC
overall length 100mm

with the following routers:
RYOBI R600, R600(N), RE601
Makita 3612(C)
Skil 1875U1



Due to the extra long length of this cutter, extra care should be taken to avoid damage. The cutter should be used to plunge rout a series of overlapping holes. See page 16.

Option 2

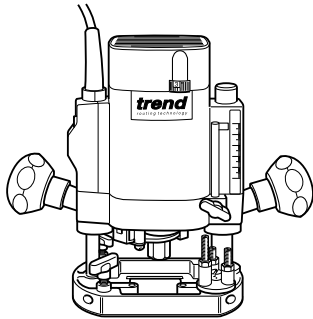

Medium duty router with
1/4" collet e.g. T5 Router

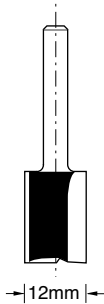

Router Cutter
Ref. TR12X1/4TC
overall length 70mm

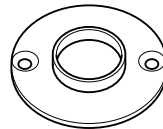

30mm Guide Bush
Ref. GB30/A

OR USE

Router Cutter
Ref. 3/8LX1/4TC
overall length 66mm

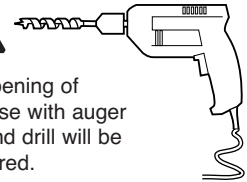

Deepening of
mortise with auger
bit and drill will be
required.

Special Note:

The jig can be used to cut the face-plate recess in the edge of doors whilst it is hung.



The mortise should NOT be routed when the door is hung. Always ensure that the door is firmly secured if routing the face-plate on a hung door, so there is no possibility of the door swinging open or shut.

Face-plate only

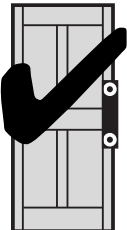

Face-plate and mortise

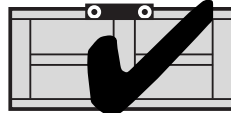

Fitting the Guide Bush

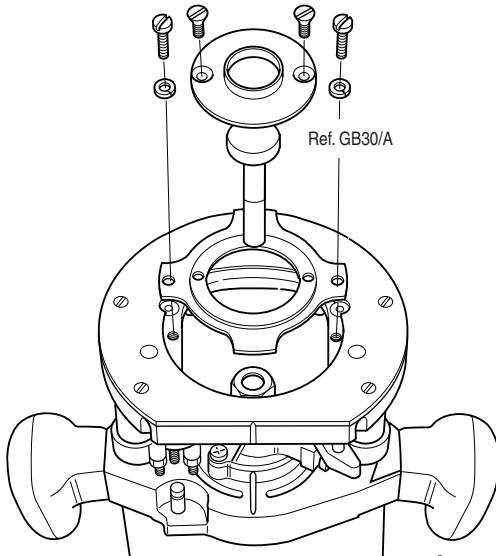

Fitting Guide Bush to T10/T11 Router

- If using the Trend T10/T11 Router, fit a 30mm guide bush Ref.GB30/A. Make sure the bush is correctly centred.



If there is any doubt about the concentricity of cutter relevant to the guide bush, then a sub-base should be used in order to ensure an accurate fit of face-plate.



Ensure guide bush collar is fitted fully onto the guide bush with chamfer facing the jig.



Frequently check that the guide bush collar is seated properly on the guide bush. Check that the collar has not worked loose otherwise this will affect the cut.

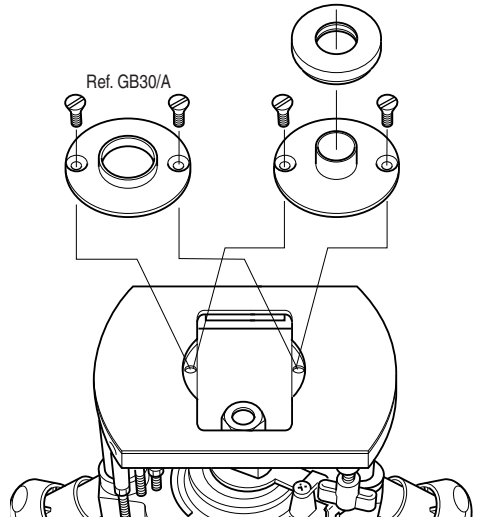

Fitting Guide Bush to T5 Router



- If using the Trend T5 Router, purchase and fit a Ref.GB30/A.
- If using the Hinge Jig, fit the GB160 supplied with the Hinge Jig. By using the Guide Bush Collar supplied with the Lock Jig, the same router set-up can be used by simply fitting the collar between the hinge and lock operations.
- The guide bush collar can be stored on the spigot fixed to the outside of the clamp bar when not in use.

OPERATION



Marking Out

- Choose the position of the lock carefully. Position the lock with the centre of the spindle aperture at approximately 1m above the floor. Whilst the lock is on the edge of the door, mark the top and bottom of the lock case on the door edge. Do not choose a position where the cross member joins the stile as it will weaken the door.
- Then using a marking gauge set to half the thickness of the door, join the marks to show where the centre line of the mortise lock will be.
- Extend the centre line with a pencil at each end of the centre scribe line to a length of 350mm so that the centre lines on the jig can be tightened in with them. These lines should be marked accurately to ensure that the jig is set correctly.
- Mark a horizontal line across the edge at the centre of your lock position. You now have two centre lines to line up with the centre lines on the jig body.



Please note, the centre of the mortise may not be on the centre line of the spindle hole.

- Mark out the spindle and keyhole position on the face of the door as normal using a paper template or the lock body as shown with a bradawl (ensuring the front of the lock is flush with the door edge).

Special Note:

If fitting the lock to a non-solid core door, ensure the lock block is located first.

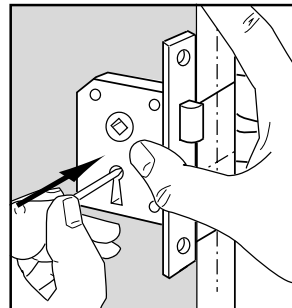
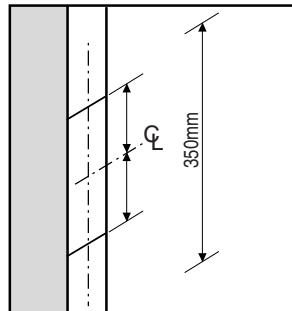
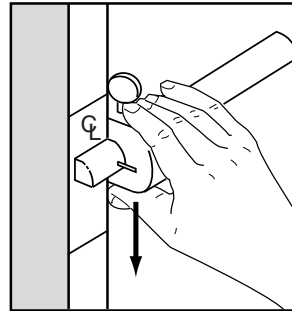
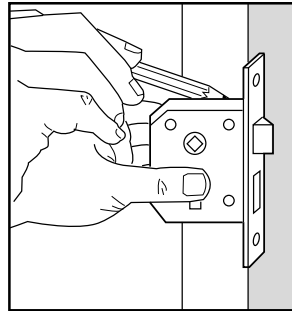

Centering the Jig

Before the jig can be used the jig must first be centralized with the lock markings.

- Loosen the clamp bar fixing screws on the jig face so that the clamp bar slides freely on the underside of the jig.
- Pull back the clamp bar to the top plate edge.
- Loosen sliding insert fixing screws and move sliding insert towards top plate edge.
- Place setting blocks in the jig recess at each end of the top plate.
- Line up engraved centre line on setting gauge with centre line on the door.
- Hold the top plate in position and tighten the clamp bar fixing screws.
- Check the centre lines correspond correctly and re-adjust if necessary.



The top plate is also engraved with a centre line and can be used to centre the jig on the door.

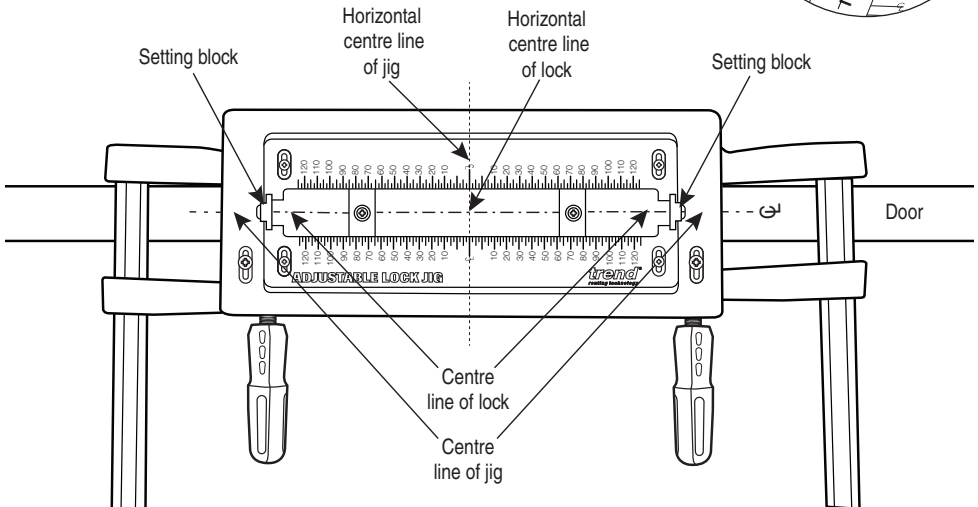
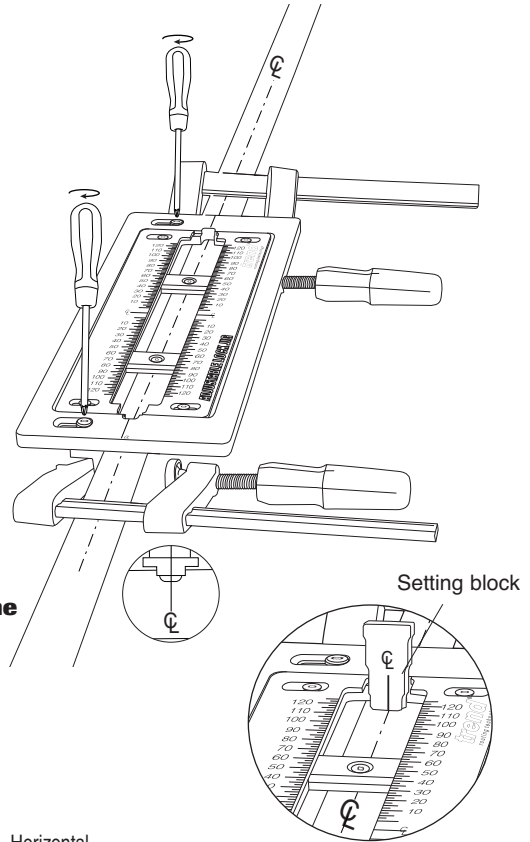

- Clamp the jig to the door with two gripper clamps mating onto each end of the edge bracket, whilst lining the centre line (⊥) across the jig with the centre line of the lock height.

The clamp heads should be fitted with pads or packing pieces to avoid marking the door. Ensure the underside of the jig is resting on the door edge.



The top plate is also engraved on the underside for doors 35mm, 40mm, 44mm and 54mm for quick set up.

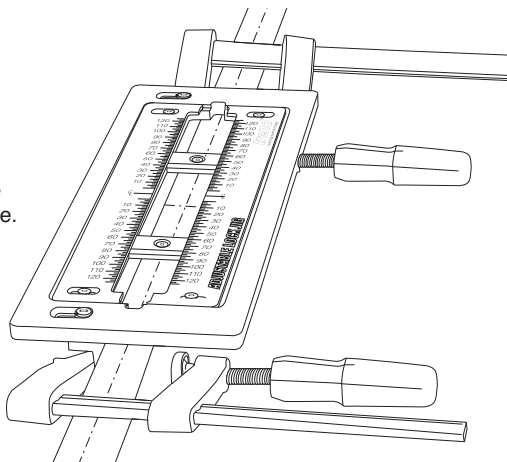

Setting the Aperture Size

The jig's sliding inserts and sliding length stops should be set up to rout the lock mortise first, then re-set to rout the face-plate of the lock, once the mortise has been routed.

- Measure length and width of the lock mechanism and lock faceplate.
- When establishing the mortise size to be routed for the lock mechanism, a tolerance of approximately 1mm is normally given to the width and up to 10mm over the length to allow clearance for the radiused corners left by the router cutter.
- It is important when calculating the mortise length, check that there will be sufficient material left to allow the fixing location on the faceplate to fix the lock in place. If not reduce the mortise calculated will match the increment sizes marked on the jig.
- For example: If lock mechanism is 15mm width x 105mm length, the mortise setting should be 16mm x 115mm. An allowance has already been made on the jig's increment scale for the offset between cutter and guide bush.

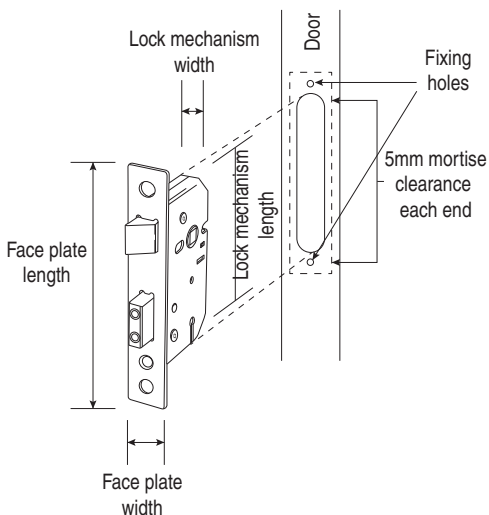

Therefore with the correct size cutter and guide bush used, the size of the mortise calculated will match the increment sizes marked on the jig.

A tolerance should not be added when setting the faceplate size.

Setting the Mortise Width 

- Loosen the four screws that hold the sliding inserts in place to enable them to slide freely.
- Line up the width mark on each sliding insert end to the required width size and tighten up the screws.
- For apertures 16mm, 19.1mm and 22.2mm and 25.4mm, a pair of width setting gauges can be used to set the width accurately, to use the setting gauges the jig may need to be lifted off the door to allow the various width stops to be used.
- Offer the appropriate width of the setting block at each end of the jig and slide the sliding inserts up to them and tighten fixing screws.
- Remove width setting gauges and store carefully.

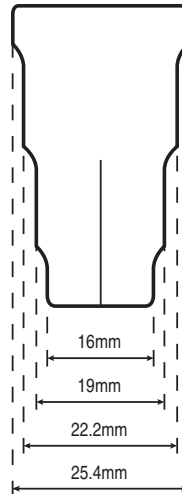
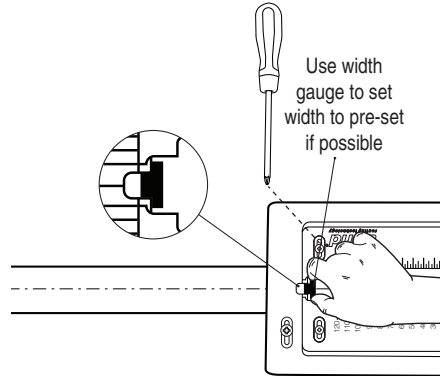

Ensure working position is comfortable, especially when setting up and when routing a door edge.



Ensure door is clamped and held securely when using the jig.

Setting the Mortise Length



- Loosen off the length stop bracket screws so that they slide easily in the jig.
- Set the length stop brackets to the required length using the inside edges as datum points. The length increment scale is set from the centre line to each end.
- For example: 120mm length mortise would require setting at the 60mm mark of each end.

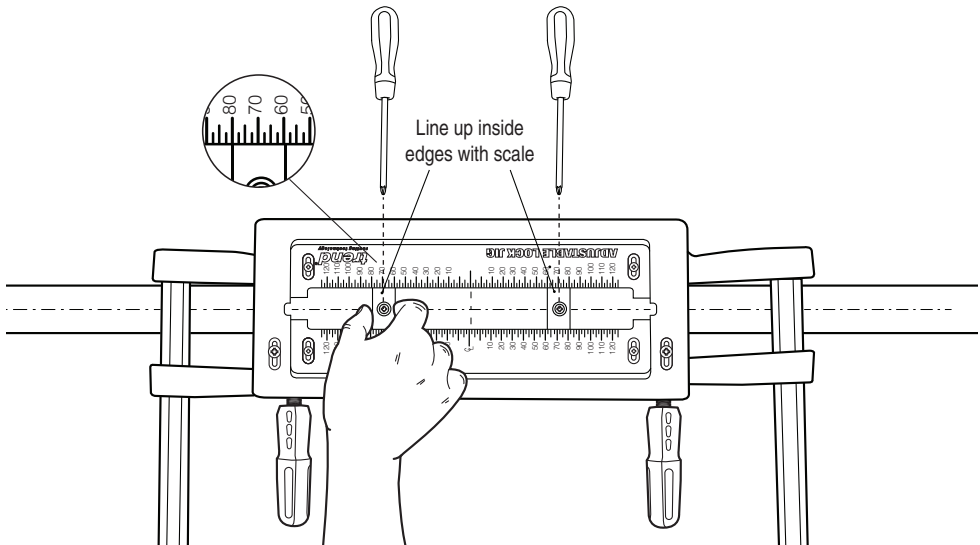

- A tolerance may be required for the mortise as mentioned previously.
- Once in position, tighten the length stop screws, ensuring the length stop brackets are square to the side cheeks.

Setting up the Faceplate Length and Width

The jig needs to be reset after the mortise has been routed.

- Whilst the jig is still clamped in position, reset the adjustable sliding inserts and adjustable length stops to match the faceplate dimensions.
- Once set tighten sliding insert fixing screws.
- A tolerance is not normally required when setting the faceplate.



Trial cuts should be made on waste material to check that the jig is set up correctly.



The result of using this jig depends on how accurately the lock markings on the door are marked and how accurately the jig is set.

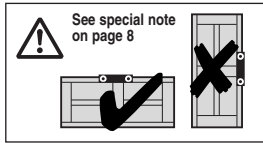

Routing the Mortise 

- Plunge rout the mortise by drilling a series of overlapping holes no more than 20mm deep.
- Make sure plunge locking lever of router is locked and then clean up by making a shallow pass no more than 20mm around the template in a clock-wise direction.
- Remove loose waste with a screwdriver and vacuum extractor and repeat plunge and rout operations until full depth is achieved.
- Depending on router set-up, deepening of mortise with auger bit and drill may be required.

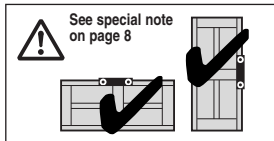

Routing the Face-plate 

- Zero the depth of the cutter, by lowering it until it touches the door edge.
- Insert the lock fixing plate together with the face-plate between the revolving depth guide and the fine adjuster screw. Lower the fine adjuster (1) and lock it off (2) see picture.
- Release the plunge locking lever.
- To rout the face-plate, plunge cutter to full depth of face-plate in the middle of the template and lock off plunge.
- Rout in a clockwise direction to the set depth. Release the plunge locking lever.

After use of the jig, remove clamp bar and store parts carefully in its packaging.

Plunge rout a series of holes

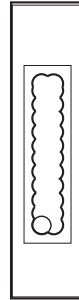

Route clockwise for clean up

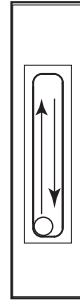

Route in shallow passes. Do not attempt to increase the depth of cut by having less than the optimum length of the cutter's shank inserted in the collet of your router. Trial cuts should be made on waste material to check the fit before routing the door.



To set cutter plunge depth measure the depth of the lock body from the face to the back and add 3mm to allow for clearance.

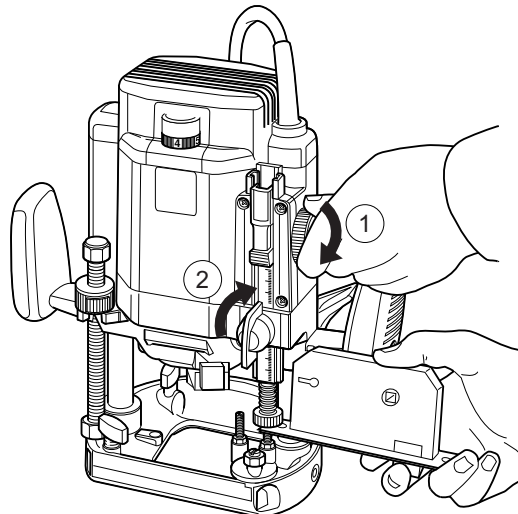

Finishing 

- The corners of the face-plate recess will need squaring off with a sharp chisel. Alternatively the Trend Corner Chisel Ref. C/CHISEL, can be used to square off the rounded corners with one tap of a hammer.

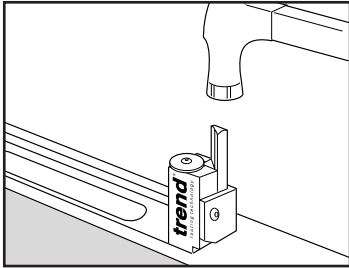

Deeper Mortise 

- Should you need to cut the mortise deeper than the maximum depth possible with the router cutter or router, use a relevant sized auger bit in an electric drill to complete the operation.

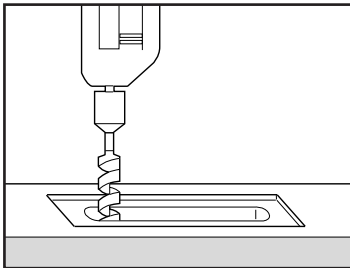

Cutting Key and Spindle Holes 

- Use a drill fitted with a suitable size drill bit to bore a hole for the spindle and the keyhole.
- Insert the lock body, test spindle and key actions then screw lock into place.
- To mark the frame to receive the striking plate, heavily mark the end of the lock bolt with a pencil. Close the door, open the lock bolt as far as it will go and gently move the door backwards and forwards.
- The pencil marks on the frame will indicate the position of the recess for the lock striking.

TIP

Before testing fit of the lock, engage the lock bolt in the locked position to enable the lock to be removed easily.

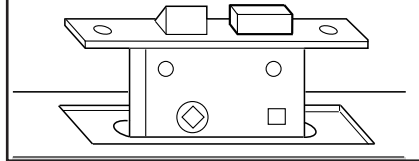

MAINTENANCE

Please use only Trend original spare parts and accessories.

The jig has been designed to operate over a long period of time with a minimum of maintenance. Continual satisfactory operation depends upon proper tool care and regular cleaning.

Cleaning

- Regularly clean the jig with a soft cloth.

Lubrication

- Your jig requires no additional lubrication.

Storage

- This jig should be stored in its packaging after use.
- An accessory case is also available Ref. CASE/DH.

ENVIRONMENTAL PROTECTION 

Recycle raw materials instead of disposing as waste.

Packaging should be sorted for environmental-friendly recycling.

The product and its accessories at the end of their life should be sorted for environmental friendly recycling.

GUARANTEE

The jig carries a manufacturers guarantee in accordance with the conditions on the enclosed guarantee card.

LOCK JIG B - SPARE PARTS LIST

v1.0 09/2013

Please use only Trend original spare parts.

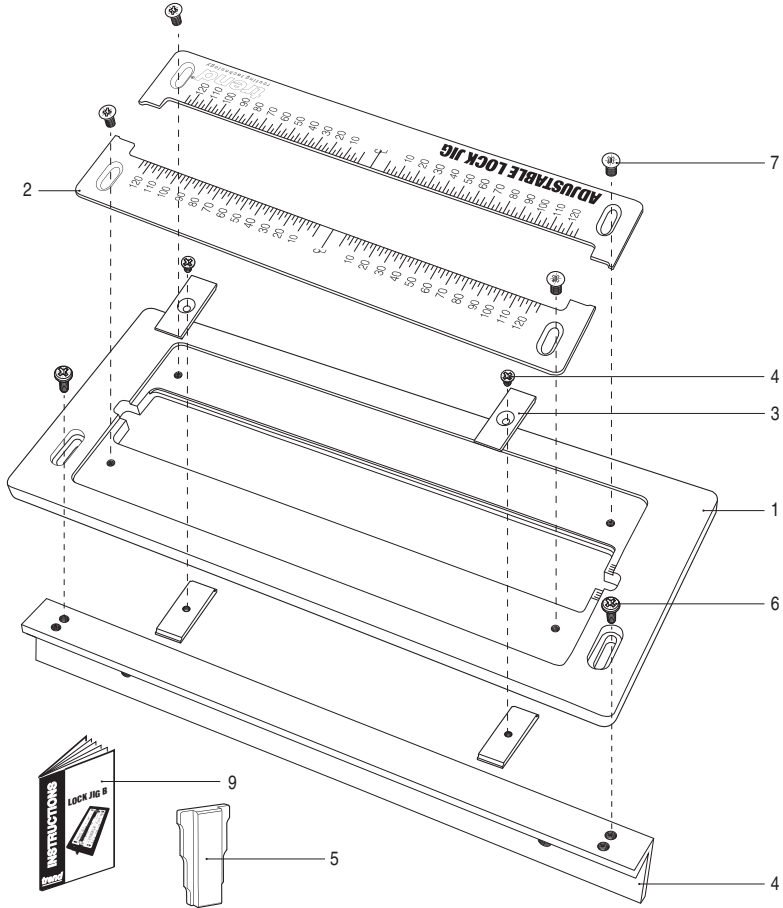

LOCK JIG B - SPARE PARTS LIST			v1.0 09/2013
No.	Qty.	Desc.	Ref.
1	1	Top Plate	WP-LOCK/B/01
2	1	Sliding Inserts (Pair)	WP-LOCK/B/02
3	2	Length Stop (Two Part)	WP-LOCK/B/03
4	1	Clamp Bar	WP-LOCK/B/04
5	1	Setting Block (Pair)	WP-LOCK/B/05
6	1	Machine Screw M6 x 16mm Pan Pozi	WP-SCW/119
7	1	Machine Screw M5 x 10mm Csk Pozi	WP-SCW/120
8	1	Machine Screw M5 x 6mm Csk Pozi	WP-SCW/121
9	1	Manual	MANU/LOCK/B

MANU/LOCK/B v1.0



RECYCLABLE

Trend Machinery & Cutting Tools Ltd.

Odhams Trading Estate St Albans Road

Watford WD24 7TR England

Tel: 0044(0)1923 249911

technical@trendm.co.uk

www.trend-uk.com